

The background of the top two-thirds of the page is a photograph of industrial machinery, likely a printing press or a textile loom. The scene is bathed in a deep blue light, creating a sense of motion and technology. The machinery features various rollers, belts, and structural frames. A large, semi-transparent blue circle is overlaid on the right side of the image, partially obscuring the machinery. A white circle is positioned at the bottom right of this blue circle, overlapping the white bar below.

**THE ENTIRE  
SPECTRUM  
FOR CURING**



The Hoenle global headquarters in Gilching, near Munich.

## HOENLE BUSINESS UNIT CURING PARTNERS OF THE PRINTING & CONVERTING INDUSTRY

We are the complete, solution-focused UV technology development partner, for solvent-free radiation curing and drying applications. We set technological trends, are well regarded for our engineering excellence and provide technology platforms to drive sustainable and resource-efficient processes.

**Our mission is to develop pioneering solutions in curing and drying technologies by combining innovation and a strong focus on customers and employees.**

We provide tailored, application-specific systems, open-technology consulting across the full spectrum – from UV, LED-UV and Inert-UV to IR, Hot Air and Excimer – and deep technology expertise, enabling energy-efficient, resource-saving, and future-ready processes. With our consulting strength and close market orientation, we are a reliable partner throughout the entire value chain.

# hoenle

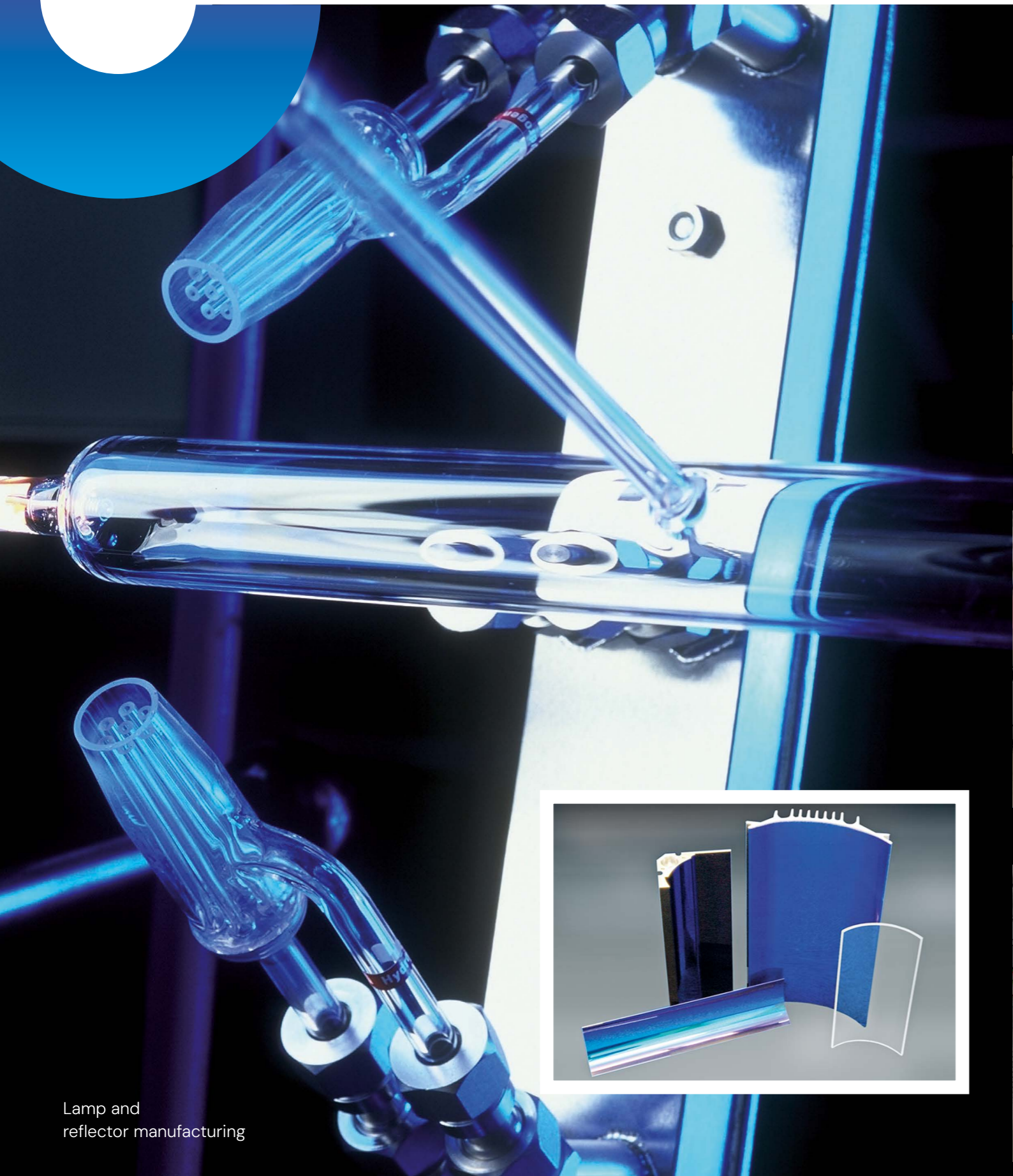

Lamp and reflector manufacturing

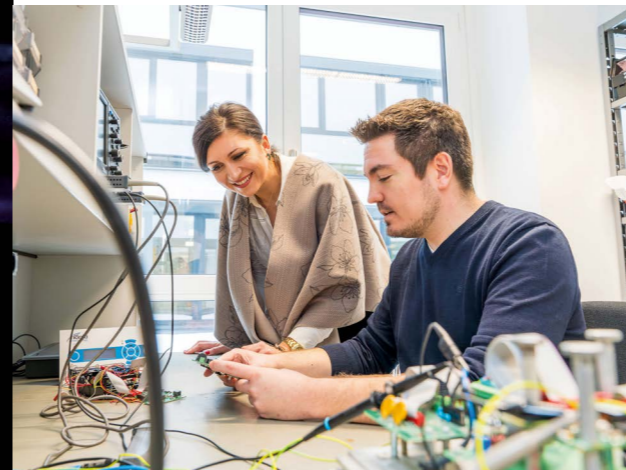

## FROM CONCEPT TO IMPLEMENTATION AND FAR BEYOND

We listen because each application and process presents unique challenges.

We understand our customers and translate their needs into top-notch products, thanks to our high competence and expertise.

We develop and manufacture the best solution, also due to our unique depth of production, particularly for the key components of our drying systems: From UV lamps and reflectors to our own LED assembly, from electronic power supply units to control cabinets, we manufacture everything in-house, and that differentiates us from others. This provides our customers with maximum flexibility and the highest quality standard.

We create innovation and value — for your application, your process, people, and the environment.

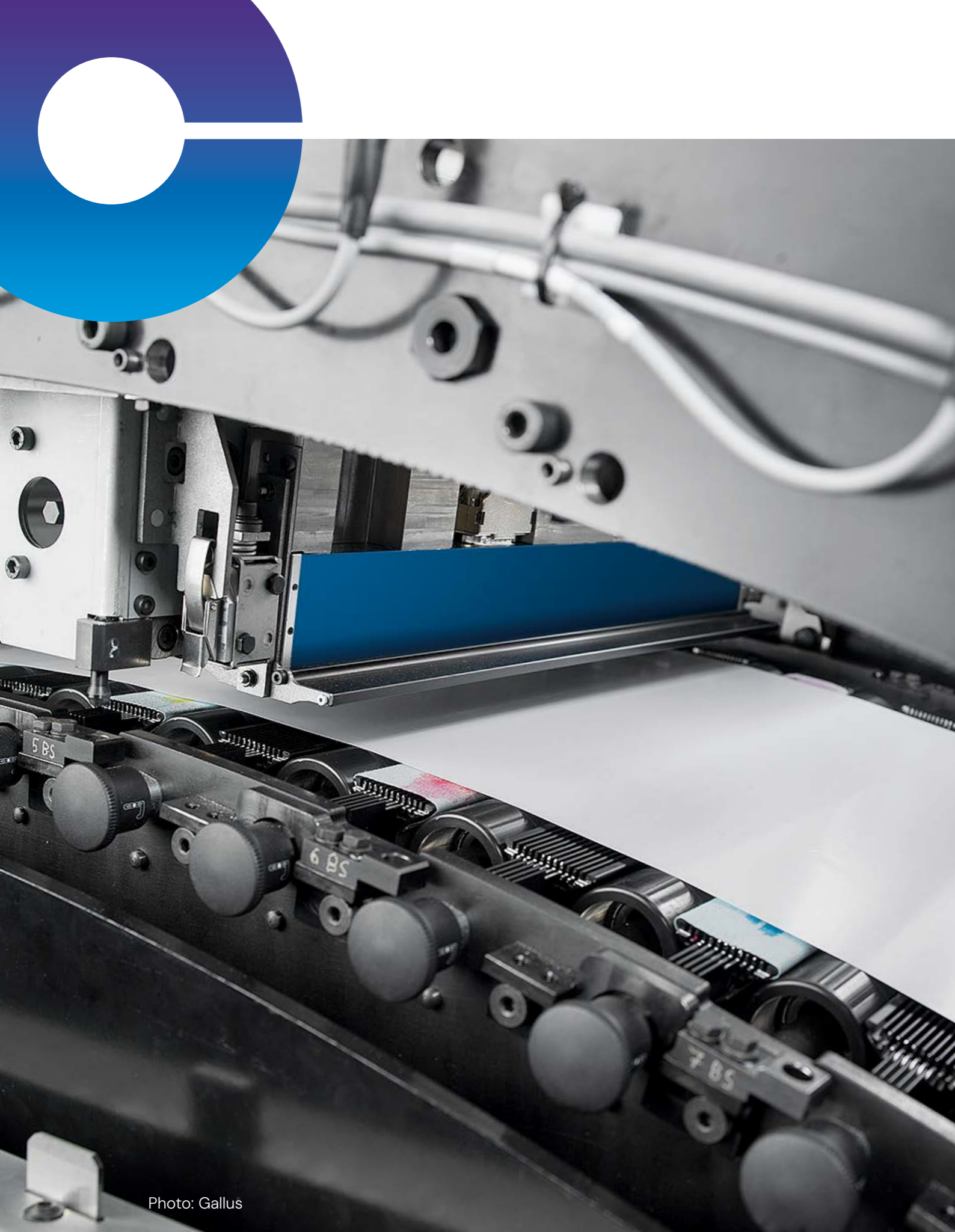
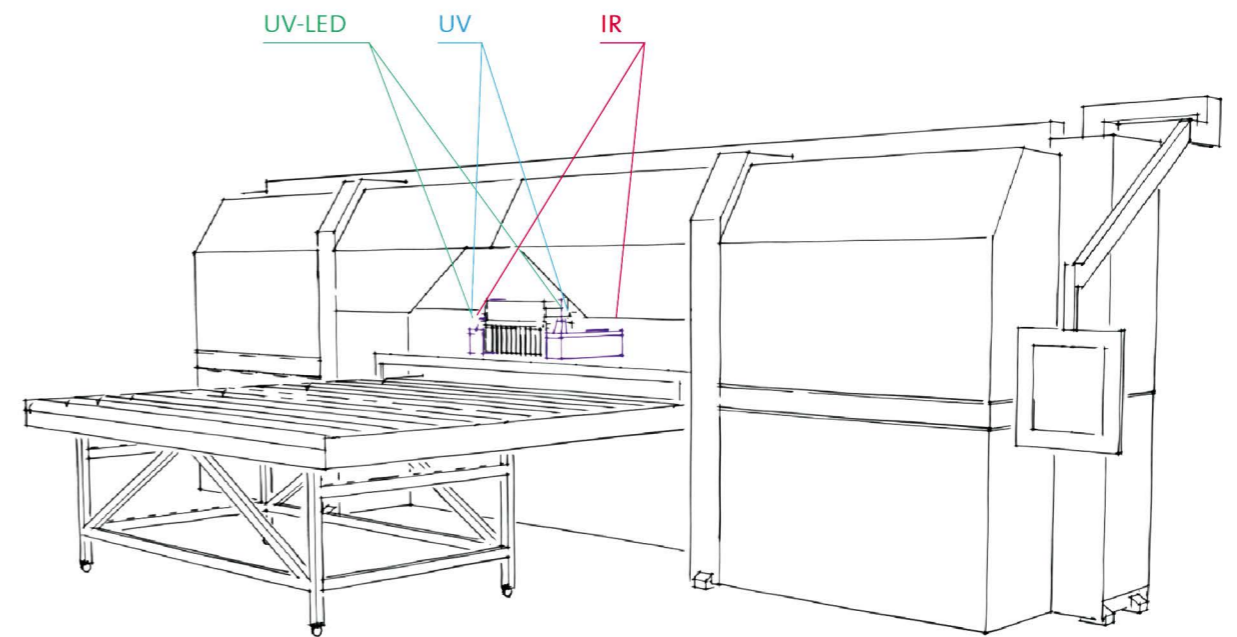

Photo: Gallus



## SOLUTIONS FOR DIGITAL AND INKJET PRINTING

In digital printing, data is transferred directly from the computer to the printing machine, which applies the inks to the substrate without a fixed printing body. This easy handling makes digital inkjet printing unique in terms of flexibility and ideal even for small print runs up to individual printing.

Whether it is conventional UV, LED-UV, or IR technology, Hoenle offers high-end dryers for every digital inkjet application, from narrow web to wide format sheetfed printing.

The UV-specific instantaneous curing enables special visual and tactile effects, resulting in visibly and tangibly better print results. Our LED-UV options allow for highly efficient outstanding UV quality – even for temperature-sensitive substrates.

Highest efficiency, maximum productivity, and future-proof sustainability guaranteed.



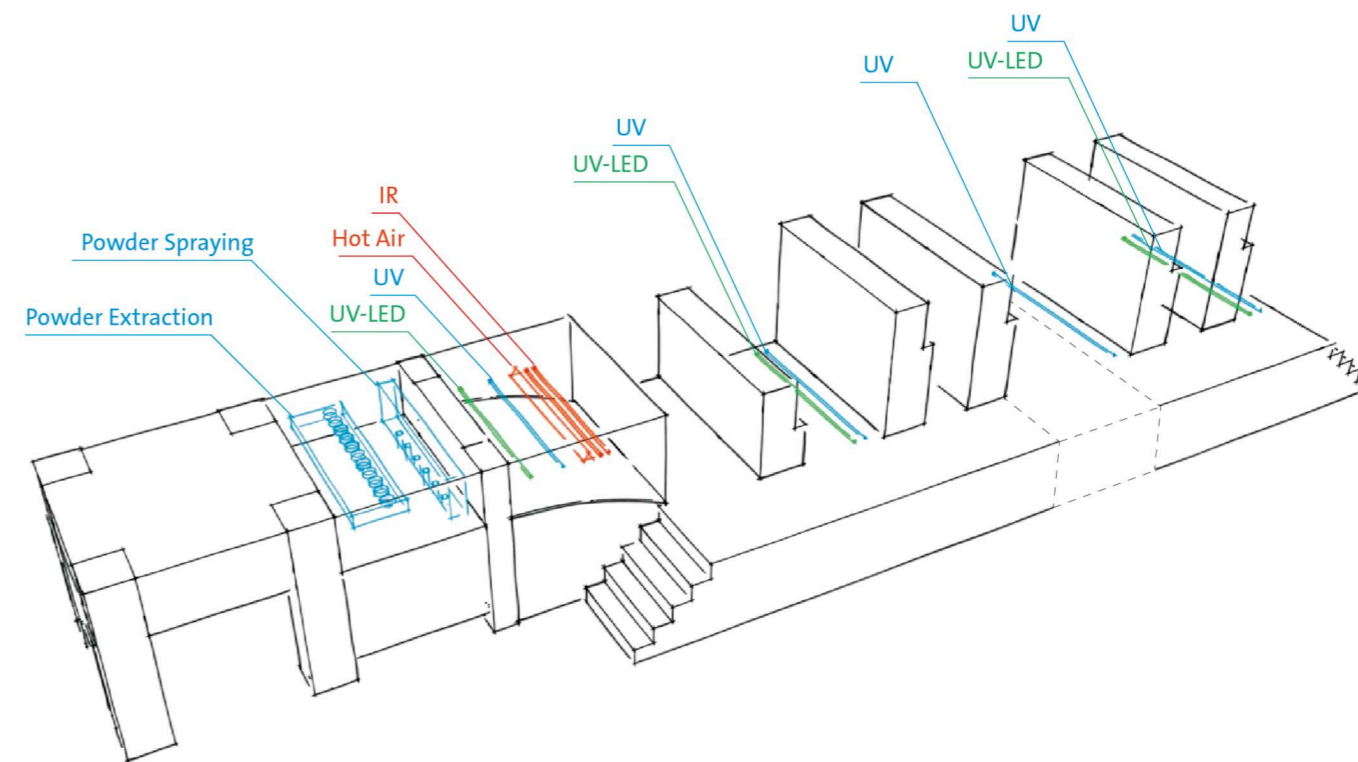
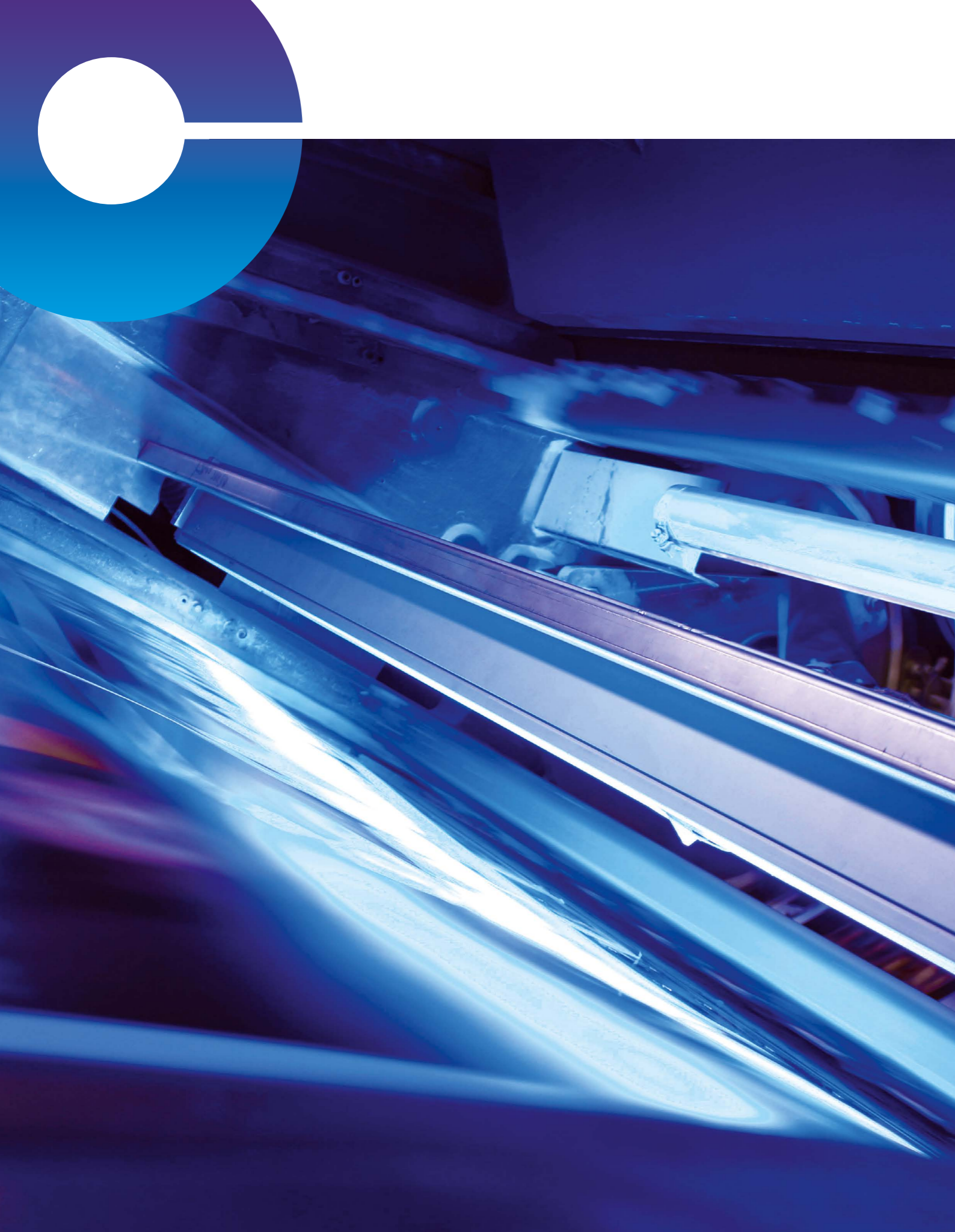

## PARTNERS FOR SHEETFED PRINTING

For smaller and medium print runs, sheetfed applications are usually the preferred choice, which – for these applications – is cost-effective, due to its high degree of flexibility. The applications are mostly in commercial and package printing, but also printed-value products such as banknotes, identity documents etc. are often produced in sheetfed processes.

Hoehnle's expertise goes beyond UV and LED curing – we're also a global leader in Powder Spray and Powder Suction technologies.

We develop and supply UV, LED-UV, infrared, and hot-air drying systems for sheetfed presses of all formats – with decades of experience and a commitment to energy-efficient, safe, and high-performance solutions.

Across all developments, we place a strong focus on energy efficiency, process reliability, and boosting our customers' productivity.



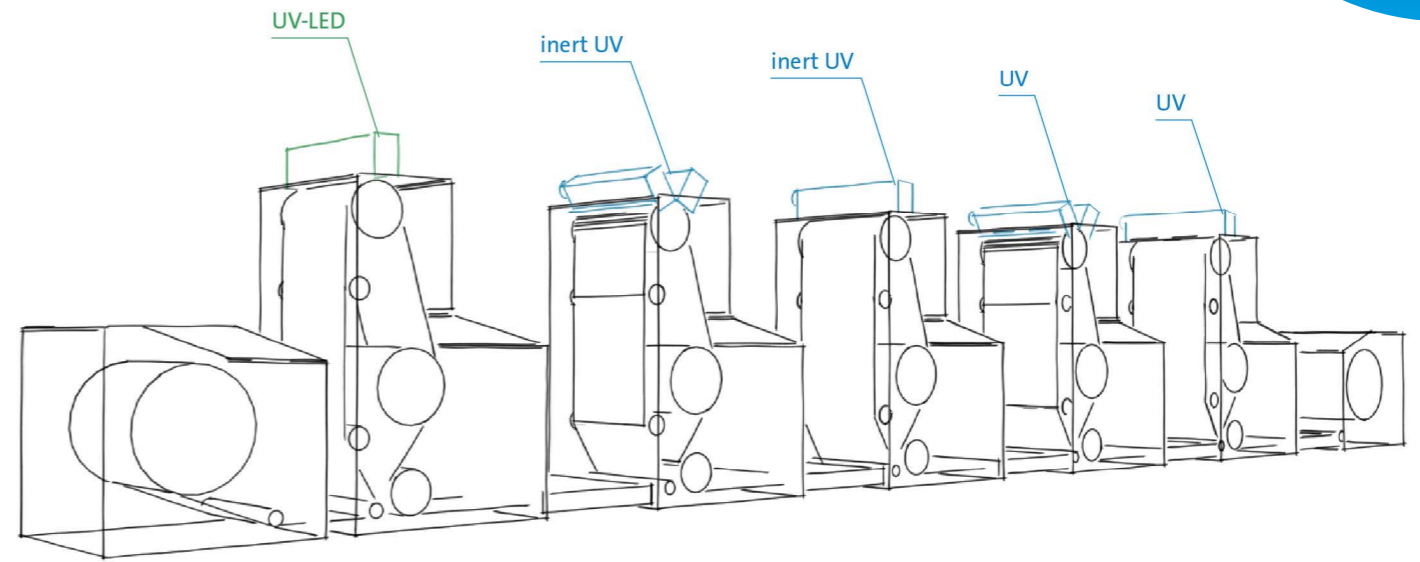

## HIGH QUALITY UV SYSTEMS FOR WEB PRINTING

For web applications the printing substrate is not fed in sheets but from a roll. The possibility of printing face and reverse sides in sequential print units simultaneously, as well as the inclusion of directly attached folding units, as well as inline processing, leads to a significantly faster production process.

UV and LED-UV technology offer the highest quality, productivity, and efficiency in web printing.

Especially in Food Packaging, inert dryers are used. They are characterized by precise measuring and control technology for inertization. This ensures safe production with low nitrogen consumption. Full cross-linking allows the reduction of photoinitiators and significantly decreases the migration of toxic substances.

The option for retrofitting, as well as hybrid UV and LED-UV modules, make the technology a future-proof solution.





## LIFECYCLE SOLUTIONS SERVICE IS AN ATTITUDE

Our collaboration with the customer does not end with the installation of the product. We take service very seriously. You need support? We are here for you – worldwide, seven days a week, around the clock, throughout the entire lifecycle of the printing press.

centralized spare parts warehouses, we are quickly on site. And if quickly is still not quick enough, we provide immediate assistance with augmented reality-based remote service. All this ensures a sustainable printing process.

Whether it is about preventive maintenance, retrofitting, or a problem occurs during the process: with service technicians stationed around the world and de-

We make sure production keeps running.

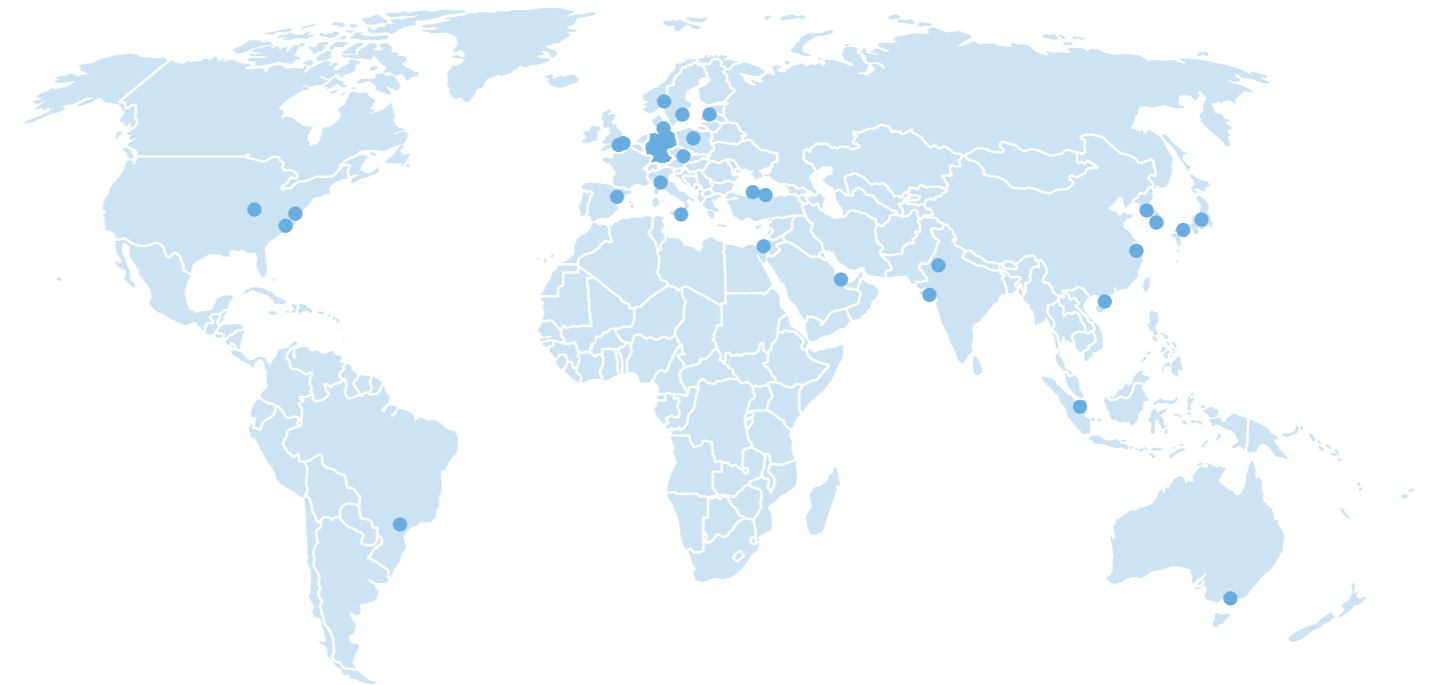

## MORE THAN THE PERFECT CURING AND DRYING PARTNER

In addition to our high-tech curing and drying systems, we offer other solutions related to the printing press.

### Solutions for UV Measurement

To maintain consistent print quality, we strongly recommend regular UV measurement. Our measurement technology enables you to check both dosage and intensity, with intuitive operation for easy, reliable results across all UV and LED-UV applications – ensuring optimal process safety.

### Powder Systems for Sheetfed Printing Machines

For decades, we have been developing and manufacturing powder application and extraction systems for sheetfed printing worldwide. Why? Because we are your trusted partner for complex, customized process solutions.



Spray bar for powder application



## TECHNOLOGICAL BASICS

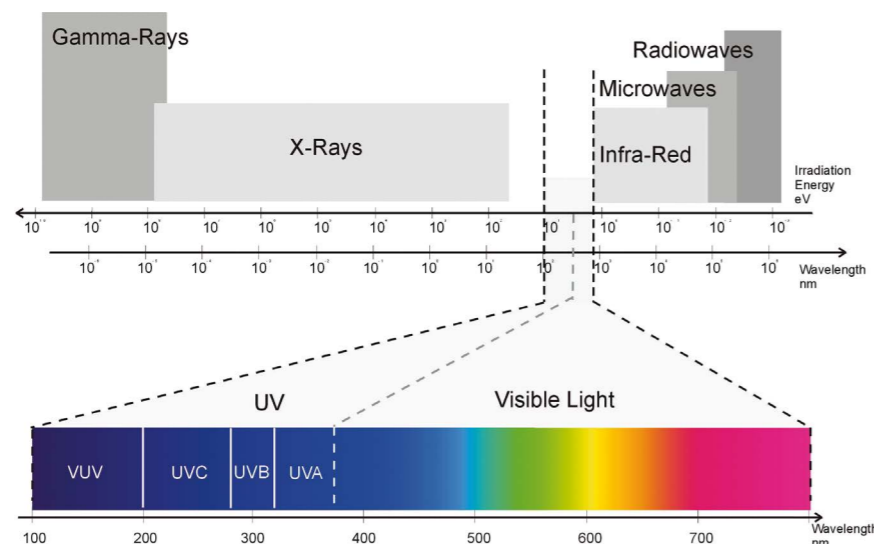

Both UV and IR radiation are part of the electromagnetic spectrum, which spans from extremely short-wavelength gamma rays and X-rays through visible light to long-wavelength radio waves.

Only a small portion of the electromagnetic spectrum — roughly 400 to 800 nanometers — is visible to the human eye. Just beyond the blue end of this range lies UV light, spanning approximately 100 to 400 nanometers — the range in which Hoenle operates.

We design systems that harness UV light for industrial cross-linking processes, such as curing paints and varnishes. Energy efficiency has always been a key focus at Hoenle, which is why we engineer our systems for

maximum radiation efficiency right from the development stage.

But we don't stop at ultraviolet. Hoenle also operates at the opposite end of the light spectrum: infrared. Starting at around 800 nanometers — just beyond visible red light — infrared radiation is ideal for drying applications and for the controlled heating of surfaces and substrates when required.

Our engineers are also actively developing innovative drying systems in this field.

## WHAT CAN UV DO? A BRIEF SUMMARY OF UV CURING

UV curing is the preferred drying technology in many printing and finishing applications. Conventional UV systems use medium-pressure lamps that generate a broad spectrum with a high UV content via high-voltage arc plasma. This radiation has the precise wavelength and energy needed to polymerize the photoinitiators and oligomers in the coatings, forming a three-dimensional network in a fraction of a second.

The use of UV inks and varnishes offers many advantages, the most obvious being the enhanced quality of the final product. Special effects — such as high-gloss finishes (up to 95 gloss units), matt effects, lenticu-

lar, color-changing, or holographic effects — can be achieved using UV technology, along with exceptional scratch resistance, to deliver a premium finish. This applies not only to printed materials like paper and cardboard, but also to plastics, aluminum coatings, and more.

Additional benefits for printers include extended “pot life” of inks and varnishes, elimination of spray powder, and the ability to process the product immediately. Together, these advantages make UV printing efficient, low-maintenance, and capable of delivering consistently outstanding results.

## PROPERTIES OF UV CURING

### Time:

The cross-linking that takes place in a split second allows immediate quality control and processing of the product.

### Energy and environment:

UV-cured coatings are typically 100% solvent-free and require neither a drying oven nor VOC disposal.

### Quality:

Chemical polymerization produces high-quality coatings with excellent chemical resistance and superior surface properties, including outstanding scratch resistance.

### Gloss:

UV-cured varnish systems routinely achieve extremely high gloss levels — up to 95 gloss units.

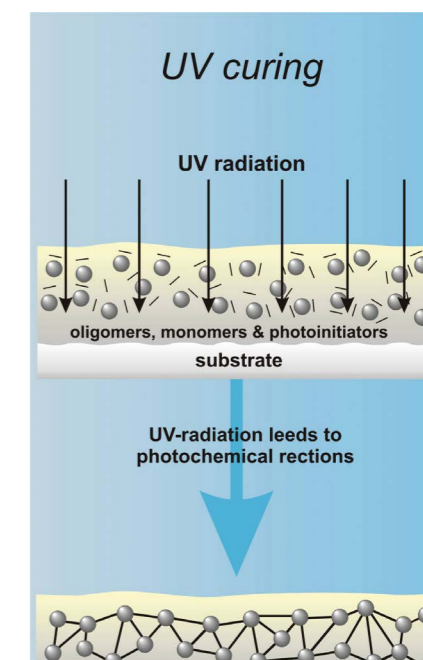

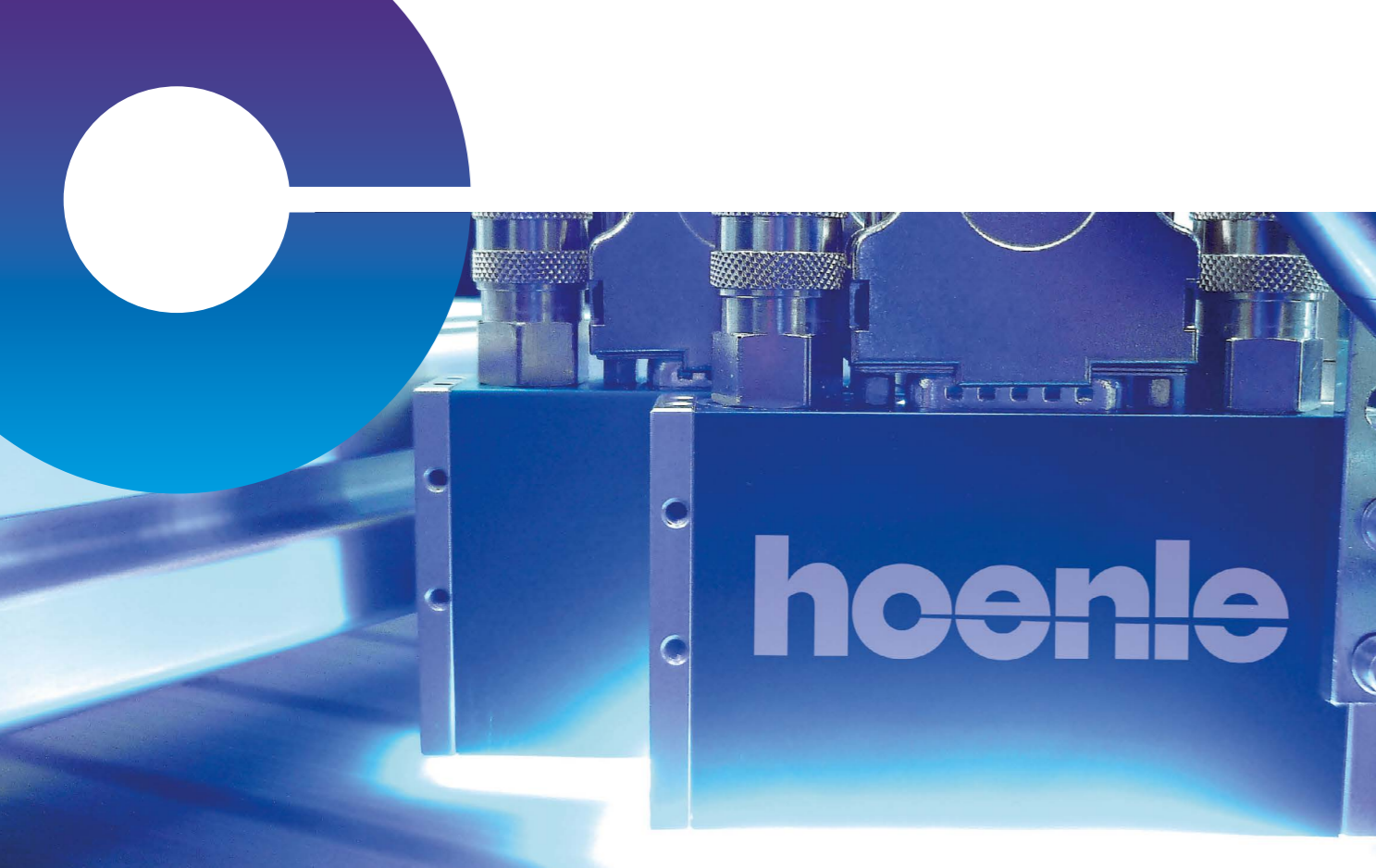

LED Powerline in application

## LED-UV CURING – A VARIANT FOR THE FUTURE

A comparatively new variant of UV curing is the use of LED-UVs. In contrast to the gas discharge technology of the medium-pressure emitters, LED-UVs are based on

semiconductor electronics. By applying voltage, the UV diodes emit a virtually monochromatic spectrum in the specific wavelengths 365/375/385/395/405 +/- 10 nm.

## PROPERTIES OF LED-UV CURING

### Space required:

Thanks to the small size of the diodes, LED units can be designed in a very compact form, saving valuable space.

### Function:

The digital operation of LEDs enables on/off cycling in the millisecond range.

### Heat:

LED-UV systems emit no IR radiation, resulting in a low thermal load during the curing process.

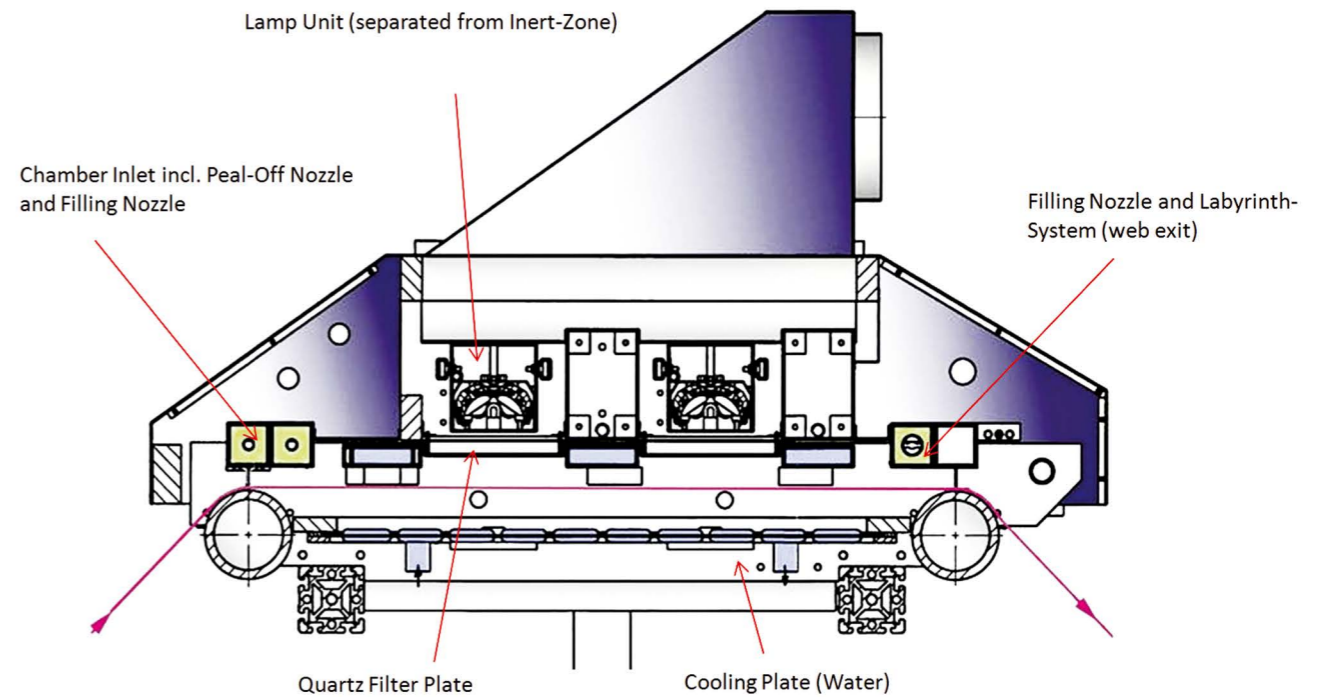
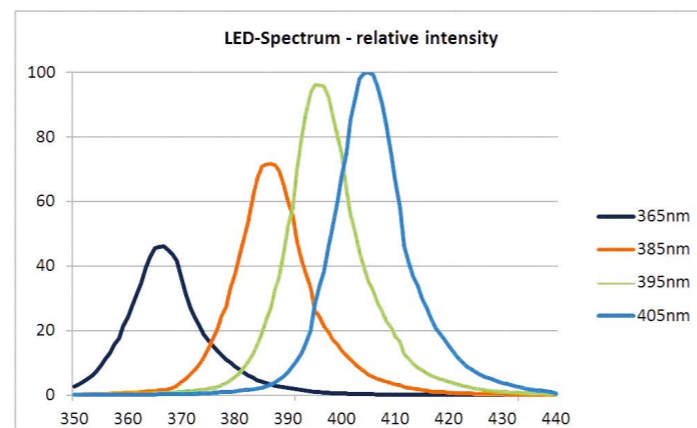

## INERTIZATION FOR UV PROCESSES

The polymerization process can be inhibited by atmospheric oxygen that is present on the surface of the coating medium during cross-linking.

This leads to lower speeds and lower degrees of cross linking. During inertization, the atmospheric oxygen is replaced by an inert gas such as nitrogen.

## PROPERTIES OF INERTIZATION

### Process speed:

Polymerization is unaffected by oxygen, which means that the line speed can generally be increased.

### Packaging:

In an inert atmosphere the amount of photoinitiators can be reduced to a minimum.

### Surface:

The surface properties, such as hardness and resistance to solvents or scratches, are increased considerably by inertization. Systems with long-wave photoinitiators can also be used with this technology. Thus inertization is an interesting variant for LED-UV curing, too.

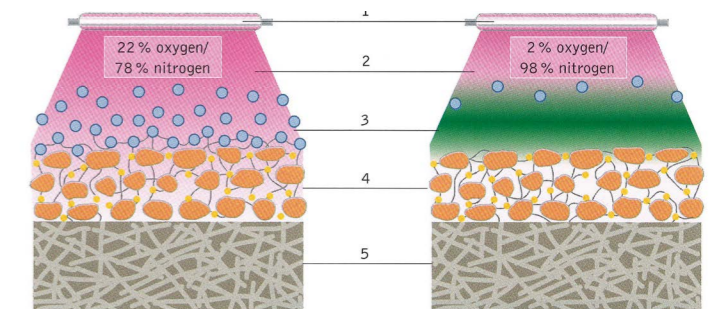

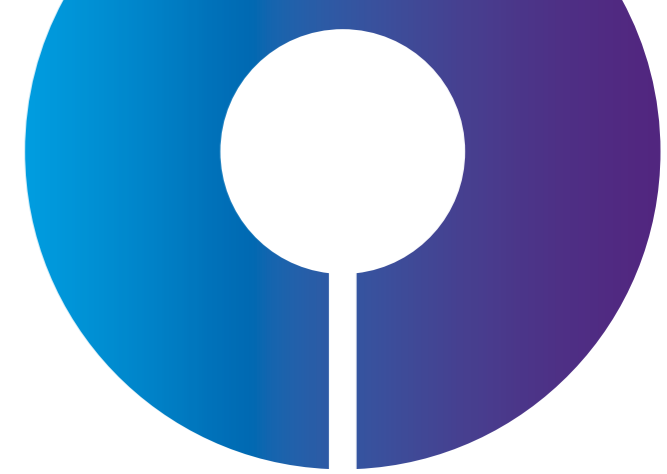

## IR / HOT AIR DRYING OF DISPERSION VARNISHES

Dispersion varnishes have a wide range of applications in the printing industry. They dry through a combination of ink penetration and evaporation. During ink penetration, the print substrate absorbs the liquid components of the varnish. To accelerate this process, an IR/hot

air dryer is used: the IR radiation vaporizes the water content, and the resulting moist air is removed via an exhaust system. Physical cross-linking during drying gives dispersion varnishes good mechanical strength and durability.

## PROPERTIES OF IR / HOT AIR DRYING

### Time:

Fast “touch-dry” performance enables maximum machine speeds and minimizes waiting times.

### Energy & Environment:

Dispersion varnishes are safe for human health and can be dried with comparatively low energy consumption.

### Quality:

Easy to process, these coating systems provide increased resistance to scratches and abrasion, while requiring significantly less powder than oxidation-dried coatings.

### Gloss:

When dried using IR/hot air clear-coat systems, dispersion varnishes can achieve extremely high gloss levels — over 90 gloss units.

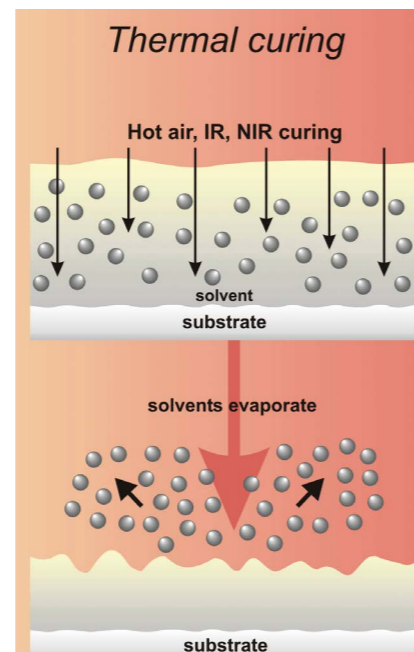

## UV COATINGS

Chemical suppliers and formulators offer UV curing formulations for many areas of the coating industry. Thus the selection of suitable UV coatings is very diverse. The applications range from UV inks, UV adhesives, silicones and varnishes through to laminations and PSAs.

For each coating and usage we configure the optimum drying system in terms of performance, spectrum and energy efficiency.

The offered range of LED-UV curing varnishes and inks for coating applications is steadily increasing. We provide perfectly adapted LED-UV systems.

IR lamps in combination with hot air are used for drying water-based inks, varnishes, adhesives, and other functional coatings. Moreover IR systems are applied for heat-reactive coatings, as for example for fusing and hardening powder coatings.

Precise adjustment of wavelength, power, and configuration to the properties of each application leads to excellent results in drying and heating processes.

## TECHNOLOGY OF POWDER SYSTEMS

The use of effective powder systems is indispensable in sheetfed printing processes that do not employ UV technology. During color printing, powder must be dosed and applied to the sheets to prevent them from sticking together. It is also used as an anti-friction agent during the further processing of coated sheets.

### Dosage:

Precise dosage ensures that only the smallest necessary amount of powder enters the printing machine, minimizing contamination. Application is carried out via a nozzle bar combined with a compressed-air feed tailored to the press. This process delivers optimal sheet stacking with the least possible powder use.

The challenge for any powder system is to ensure consistent application across the sheet — at any printing speed and for all format classes.

### Exhaust:

To complement our powder systems, we also supply dedicated powder exhaust systems for sheetfed printing.



# hoenle

## Global Headquarters

Hoenle AG  
Nicolaus-Otto-Str. 2  
82205 Gilching  
Germany

T: +49 8105 2083 0  
curing@hoenle.com  
www.hoenle.com

## Location Kohlberg

Hoenle WebCure GmbH  
Philipp-Jakob-Manz-Str. 18  
72664 Kohlberg  
Germany

T: +49 7025 91277 0