

# BLUEPOINT LED ECO



## LED POINT SOURCE WITH PROCESS FLOW CONTROL

Max. irradiation intensity:  
up to 20.000 mW/cm<sup>2</sup>  
Wavelength:  
365, 385 and 405 nm

## FEATURES

- LED power output separately adjustable
- Clean room compatible
- Processing of temperature sensitive materials
- Entry of complete program sequences
- Signal input for safe switch-off

## BENEFITS

- Reduction of maintenance costs
- Extremely long service life
- Intelligent power control
- Compact size
- Excellent cost performance ratio

## BLUEPOINT LED ECO

bluepoint LED eco has been developed for all applications requiring a most intensive UV irradiation. Thanks to its high intensity and the possibility to program complete process sequences, shortest cycle and machine throughput times can be realized especially in fully automated production lines. Likewise, bluepoint LED eco can be used in the laboratory for manual irradiation. The typical service life of a LED is longer than 20,000 hours\*. LEDs can be switched on and off as often as necessary, they do not require a warm-up or cooling phase. The emitted wavelengths are 365/385/405 nm +/- 10 nm. It is thus possible to adapt the intensity to any application in question. Up to four LED heads can be connected to the very compact control unit which can emit different wavelengths. Each LED head can be activated separately. bluepoint LED eco autonomously recognizes the type of LED head and adapts all parameters automatically.



LED control unit

### APPLICATIONS

bluepoint spot sources are appropriate for various applications like:

- Bonding, fixing or encapsulating of components in the electronic, optical or medical-technical sector
- Fluorescence stimulation for materials testing; suitable for automatic image processing
- High-intensive UV irradiation in the chemical, biological and pharmaceutical sector
- UV irradiation for different applications in a clean room

### LED CONTROL

The irradiation time can be adjusted separately for each LED head in the range between 0.01 and 9999 seconds. The alternative is a continuous operation. With a very long non-stop irradiation with high LED-intensities, an additional passive cooling of the heads may be necessary.

For each LED head, the main information, like operating state, temperature or irradiation time, is shown on the display. The electric LED power output can also be adjusted between 10% and 100%, in 1%-steps.

The unit registers the LED operating hours as well as LED temperatures and switches off the unit in the event of a fault. The operating state of each LED is indicated by bright signal lamps which can be read easily even at longer distances. bluepoint LED eco offers different modes of power control:

- In the standard power-mode a value between 10% and 100% is forced.
- The ConstPower-mode allows an almost constant optical output. In this mode the irradiation intensity is kept constant over a broad temperature range.
- For a short time irradiation with longer breaks between separate irradiation cycles, the optical output can be maximized in the PeakPower mode.
- The Step-mode allows individual irradiation sequences, just as the customer requires. Thereby, a sequence is created out of a maximum of four steps (time/power).

### PROCESS FLOW CONTROL

With bluepoint LED eco, complete process sequences can be programmed. They can be entered through the control system or by transferring a text file compiled on PC. The following sequences can be programmed:

- Exposure series with different intensities
- Activation of external handling components
- Holding times
- Conditional commanding depending on external control signals

### INTERFACES

bluepoint LED eco has the following interfaces:

- PLC inputs: 4x LED on (can optionally be assigned to one or more LEDs)
- PLC outputs: 4x status LED with selectable function (LED on, LED off, LED error, LED warning)
- 24 V digital output with selectable function (unit on, unit error; LED on etc.)
- RS 232 interface for programming the operating parameters, for operating the unit with PLC or PC, for transferring program sequences or for downloading the update of the operating software
- Release safety circuit
- Signal input for safe LED switch-off according to current safety guidelines

### ACCESSORIES

The functional range of the bluepoint LED can be extended by using optional accessories:

- Adapter for 90° beam deflection for the use in constricted room
- Extension cable in different lengths
- Adapter for the operation of up to four foot switches
- Adapter for the simultaneous operation of two control units with one foot switch



LED head

### TECHNICAL DATA

LED service life	> 20.000 hours**
Max. UVA intensity	up to 20.000 mW/cm <sup>2</sup> **
Adjustment range of timer	0,01 – 9999 sec or continuous operation
Wavelengths	365, 385, 405 nm +/-10 nm
Power supply 20 V – 28 V DC	20 V – 28 V DC or power pack
Max. input current	3,5 A
Dimensions (H x W x D)	65 x 160 x 130 mm
Weight	approx. 0,5 kg

\* typical lifetime under specified operating conditions depending on the LED head used, measured with Hoenle UV meter with LED sensor

## LENS TYPES FOR BLUEPOINT LED HEAD HP

Optic 3

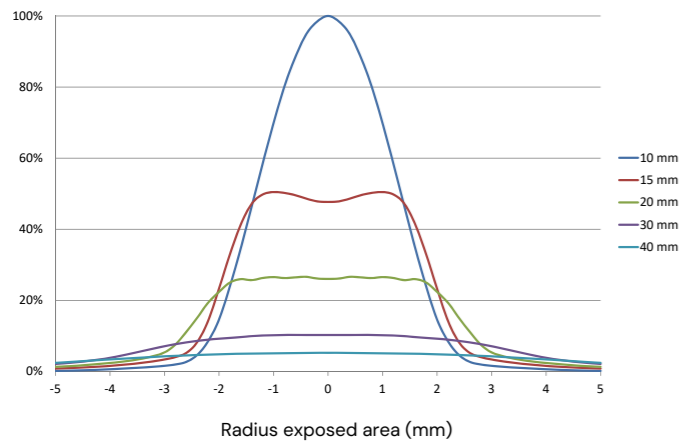

Wavelength (nm)	365	385	405
Intensity* (mW/cm <sup>2</sup> ) at 100%	14.000	20.000	20.000
Working distance (mm)		10	
Full-width at half maximum (mm)		3	

Optic 7

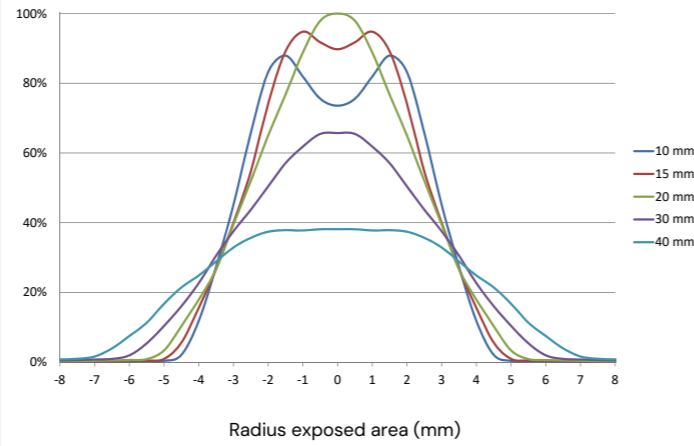

Wavelength (nm)	365	385	405
Intensity* (mW/cm <sup>2</sup> ) at 100%	4.000	4.800	3.800
Working distance (mm)		10	
Full-width at half maximum (mm)		7	

Optic 10x2 (rectangular)

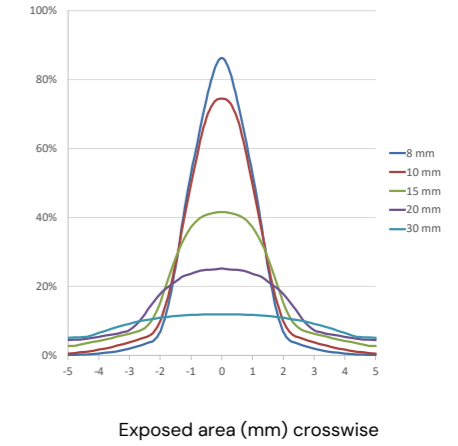
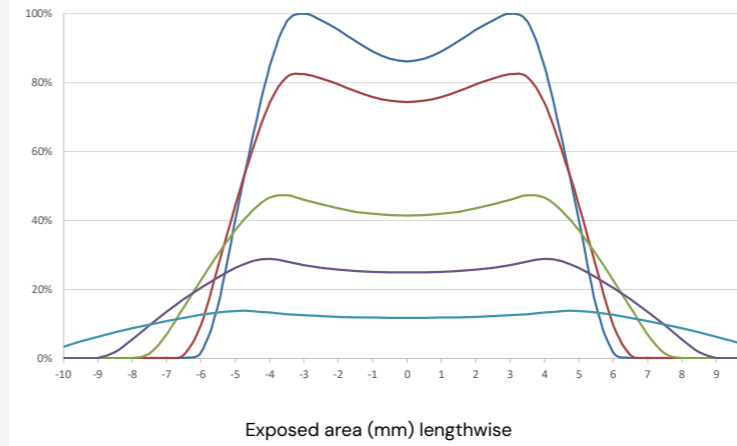

Wavelength (nm)	365	385	405
Intensity* (mW/cm <sup>2</sup> ) at 100%	4.500	7.000	7.000
Working distance (mm)		10	
half-width, crosswise (mm)		2.5	
half-width, lengthwise (mm)		10	

\*measured with a Hoenle UV meter and LED light guide sensor L2

Optic 10

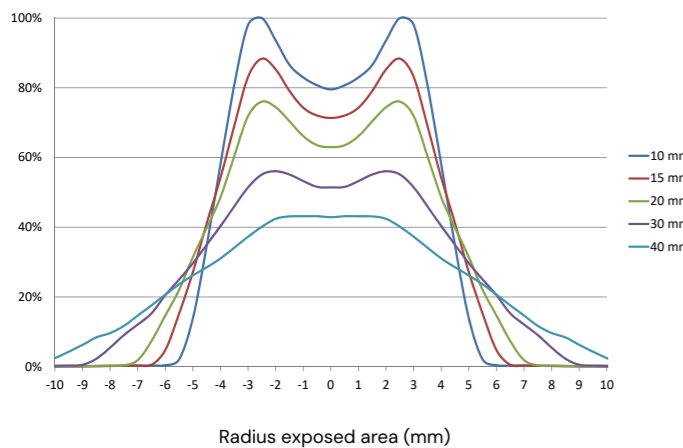

Wavelength (nm)	365	385	405
Intensity* (mW/cm <sup>2</sup> ) at 100%	2.000	2.600	2.400
Working distance (mm)		20	
Full-width at half maximum (mm)		10	

Optic 20

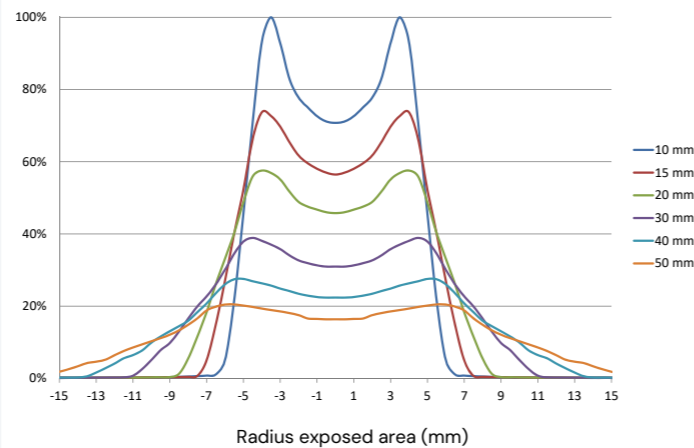

Wavelength (nm)	365	385	405
Intensity* (mW/cm <sup>2</sup> ) at 100%	1.450	1.850	1.650
Working distance (mm)		40	
Full-width at half maximum (mm)		20	

Drawing LED head HP

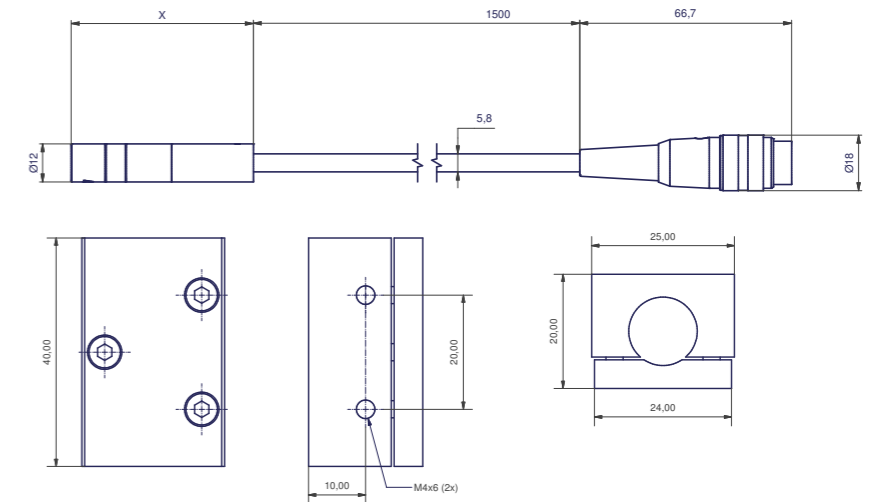

Mounting adapter LED head HP

Lens type	Length LED head HP (x) in mm
Optic 3	55.9
Optic 7	57.3
Optic 10	54.5
Optic 20	52.5
Optic 10x2	55.4

\*measured with a Hoenle UV meter and LED light guide sensor L2

## MORE HOENLE LED-UNITS

Water cooled type 

Air cooled type 



### LED Spot W

The LED Spot W allows an extremely high UV intensity output – and requires only a very small amount of space.



### jetCURE LED

Modularly controll- and changeable (grid 41 mm) as well as continuously adjustable. Available in two versions which differ in their cooling air duct.

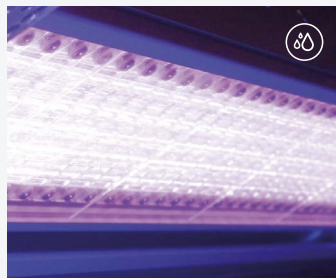

### LED Powerline Focus

Almost distance-independent high intensity due to focusing optics.



### LED Spot 40 IC

The LED Spot 40 IC was developed for all applications requiring a compact flood unit with high intensities.



### LED Powerline AC/IC

Air cooled high-performance UV LED array optional with LED powerdrive IC.



### LED Power Pen 2.0

This handy LED point source is available in the wavelengths 365 nm and 405 nm. Depending on the wavelength it is able to generate UVA-intensities of either 10.000 mW/cm<sup>2</sup> or 16.000 mW/cm<sup>2</sup>.

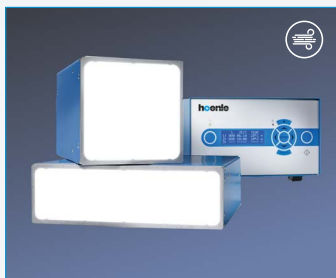

### LED Spot 100 IC / 100 HP IC & LED Spot 200 HP IC

The light-emitting aperture has a size of about 100 x 100 or 200 x 50 mm. For bigger irradiation fields, several LED Spots can be arranged modularly.



### LED Powerline LC

Maximal length depends on application (lengths variable in 40 mm-steps). The LED Powerline LC is available in the wavelengths 365/385/395/405 nm.

**Hoenle AG**  
Nicolaus-Otto-Str. 2  
82205 Gilching  
Germany

Phone: +49 8105 2083-0  
equipment@hoenle.com

www.hoenle.com



Operating parameters depend on production characteristics and may differ from the foregoing information. We reserve the right to modify technical data.  
© Copyright Hoenle AG. Updated 09/25